

on the job/off the job

G.F. Rogers

Bringing radio to the rural home

In the early thirties, radio was far from omnipresent, so an innovative cable system was developed to extend the reception of a single receiver to hundreds of families in a rural area.

Abstract: *Surrounded today by many examples of advanced communications technology, we may forget or be unaware that these services have not always been at our beck. Radio, of course, was the medium at the start of the second quarter of this century, at least for urban areas. Rural communities, with their far-flung populations, were another story. This article describes how a unique cable distribution network was developed to extend the reach of radio into several rural counties in northwestern South Carolina in the early thirties.*

In the winter of 1930-31, I became dissatisfied with the low-powered uneconomical battery radio set used in my home and reconditioned an old alternating current set. It occurred to me that I might serve from my receiver, a neighbor who had no electric service. By installing a single wire with ground return, I connected the neighbor's loudspeaker to my receiver. The results proved so satisfactory that

Reprint RE-26-1-14

Final manuscript received June 11, 1980.

others became interested and, within a month, the service was extended to seven families. In about four years, 600 homes were being served. This required 400 miles of single-wire transmission lines extending over three counties, with the most distant customer 24 miles from my receiver.

To improve the service and maintain volume and high fidelity tone quality over this rapidly expanding system, an immense amount of development work was required, supplemented by new equipment, adequate test methods, and protective relays.

The initial system

The first ac receiver used in the system had seven tubes; four type 26, one type 27, one type 71-A, and one type 80. The maximum audio output of this receiver was 0.7 watt, and the sensitivity was so low that it was very difficult to receive even the strongest stations in the daytime. In the winter of 1931-32, I built a superheterodyne receiver using tubes in the 50 series for the r.f. and i.f. stages and a type 47 for the output. The 47 output tube provided a maximum out-

put of 2.5 watts under proper load conditions. However, with all the speakers coupled in parallel through a choke-

Ed Note: Anniversaries are milestones for looking ahead and for looking back. We, in the technical community, are aware of the rapid growth and diversity of technology and have seen these changes reflected in the pages of the *RCA Engineer*. In this 25th anniversary issue of the *RCA Engineer*, Bill Webster of the RCA Laboratories takes the role of prognosticator and views the prospects for technology in the next 25 years. It is also appropriate that we get a sense of what the state-of-the-art in electronics was like 25 years before the *RCA Engineer* came into existence. Gordon Rogers, formerly of CE and now retired, takes us back and gives us a sample of innovation and experimentation in the good old days of the 1930s.

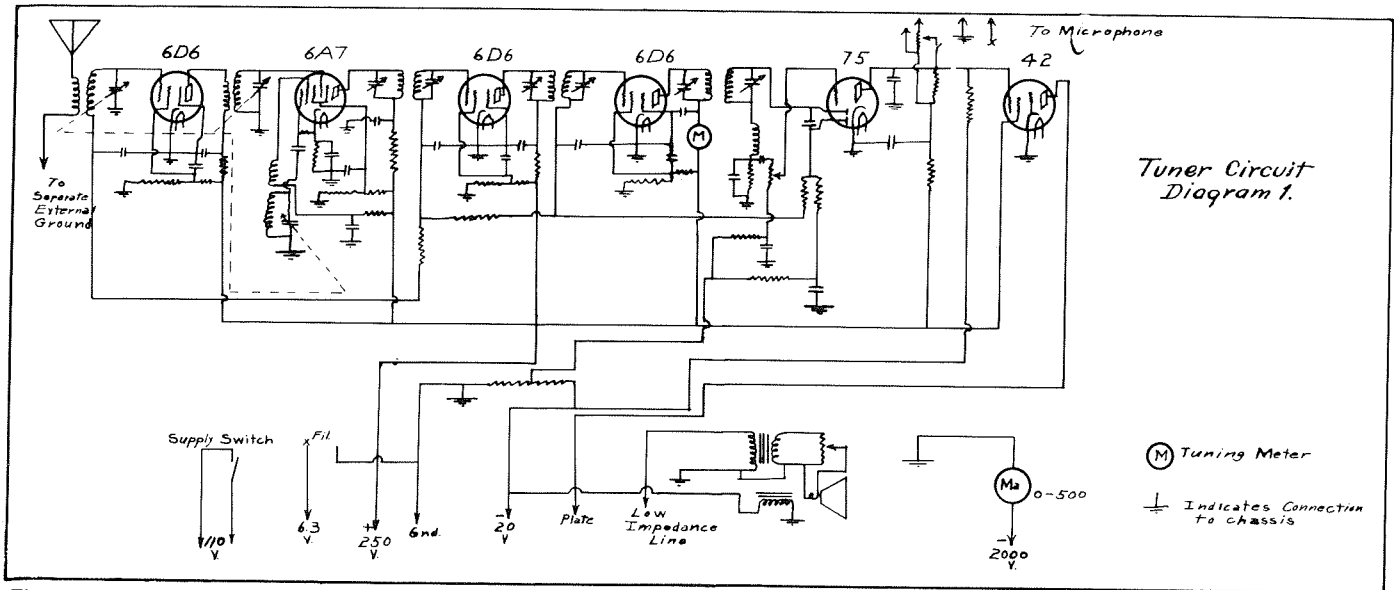

Fig. 1.

capacitor circuit, the load impedance and consequent output were low. About six months later, I installed a single 2A3 triode output tube in place of the 47 pentode and utilized more of the rated output. Precautions had to be taken with this set to prevent the i.f. from getting through to the line from whence it could return to the aerial and cause i.f. feedback.

A little later, the output power was increased to 15 watts by using two 2A3s in push-pull, and a hand-wound output transformer was used to couple them to the line. The power increase and the improved matching impedance made it desirable for each subscriber to have volume control on his speaker. A 10,000-ohm 2-watt potentiometer was used at first; but as the output was increased and the line losses became more important, these controls were changed to 25,000 ohms. This change also eliminated the tendency of the 10,000-ohm controls located on the near end of the line to burn out. Some distortion occurred when using the 25,000 ohm controls, but the listeners were far from critical, and the savings in power was important.

System expansion and power growth

At this stage, the line was about five miles long and served 15 subscribers. The appearance of magnetic cone speakers, selling at \$2.85, gave a sudden impetus to the growth of the system. Within the next four months, the number of subscribers increased to more than two hundred, at which time the supply of "bargain" speakers ran out.

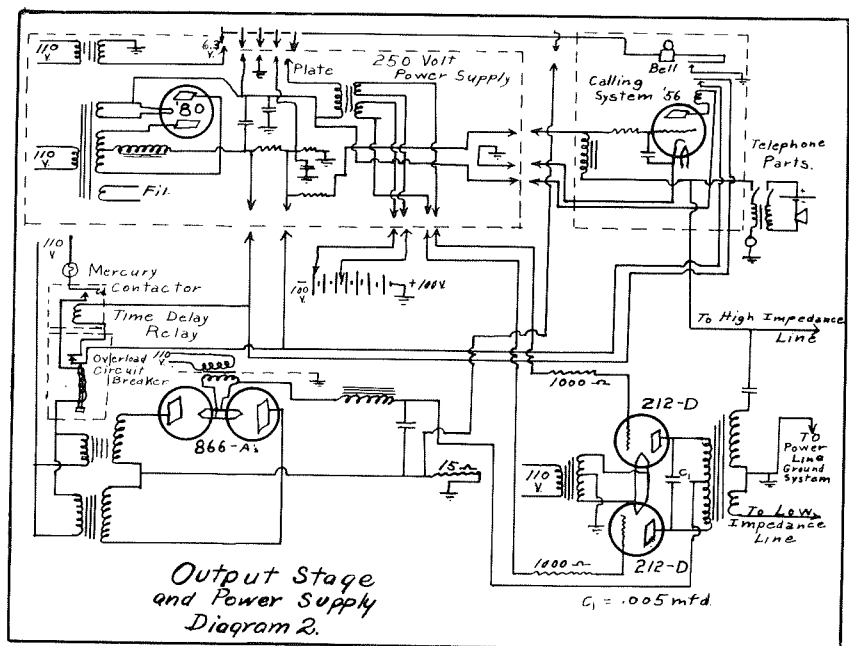

Fig. 2.

This comparatively rapid expansion of the system necessitated frequent changes in the output system, which increased successively from two to four and then to eight 2A3s in push-pull parallel operation, the output power being 15, 30, and 60 watts, respectively. A total of twenty-one tubes were now being used in the receiver.

But, it was soon apparent that 60 watts of audio power was inadequate for operating the two hundred speakers, some of which were now located as much as 15 miles from the radio receiver. Therefore, two 830-B (60-watt) tubes were substituted for the 2A3s in the output stage, operating on a plate voltage of 1000 to 1250 volts. The

2200-volt plate supply transformer, the filament transformer, the filter choke, and the input and output audio transformers were designed for these tubes and wound by hand. The plate supply transformer was dried by being placed in a vacuum, and then impregnated with hot beeswax and rosin under pressure. Previous experience with shorts and burnouts in the higher voltage transformers had indicated the need for such treatment.

The two 830-Bs would not stand up under the service demanded of them, however, and about a year later, two 204-A (500-watt) audio amplifier tubes were purchased second hand. But these also

proved unsatisfactory and were discarded in favor of two 212-Ds, (250 watt tubes). The combined audio output of these tubes ran between 350 and 400 watts. Obsolete 1-kilowatt pole transformers were bought from a local power company and used to supply the plate voltage through two 866-A rectifiers. The filter system had a choke input to reduce noise from the rectifier system. A partially rewound distribution pole transformer was used as the audio output transformer for the 212-Ds.

Next, the tuner was redesigned and brought up to date. It was rebuilt with a 6D6 pentode as the rf amplifier, a 6A7 as the first detector and oscillator, 6D6s in the two i.f. stages, a 75 as the second detector and first audio amplifier, and a 42 as a triode amplifier feeding the grids of the 212-D tubes in Class A prime. Air dielectric capacitors were used to tune the i.f. stages. These designs of the tuner and audio system are shown in Figs. 1 and 2.

Calling system feature

When the system was in its infancy and only the immediate neighbors were connected, it was desirable to be able to talk to them from time to time. To do this, I developed a switching system which would disconnect the monitor speaker from the output stage and connect it to the audio input. The operator could talk into the speaker, using it as a microphone, and the voltage generated would be amplified by the audio system and fed into the line. When the operator had finished speaking, the speaker was switched back to its normal place in the output and the line was connected to the audio input instead of the output. Anybody on the line could then talk into a speaker and be heard by the operator.

However, the person on the line had no method of talking to the operator unless the operator called first. To attract the attention of the operator, a "calling system" was devised (Fig. 3). The line was isolated from direct current by putting a capacitor, C₂, in series with the output winding and one in series with each speaker (Fig. 3) for connections. A negative potential from a dc source was placed on the line through a high-resistance, R₂. A type 27 tube was connected to a two-coil magnetic speaker with one coil in the grid lead and the other in the plate lead. The grid return was connected through a filter, (to block the audio) to the line. When a person on the line wanted to call the operator, closing a switch shorted the

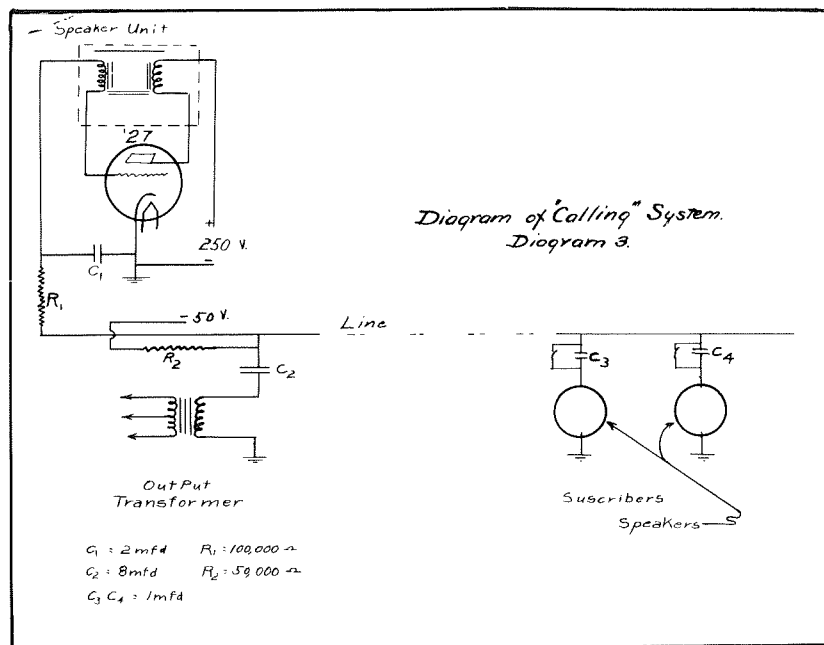

Fig. 3.

capacitor at the caller's speaker. This removed the negative bias from the type 27 tube and permitted it to oscillate at audio frequency due to the coupling of two coils of the speaker unit. The speaker, of course, responded to the fluctuations in plate current and its sound alerted the operator.

As the number of speakers increased, it became more difficult to hear the voice signal. Also, the hum resulting from grounds in the power system was strong enough to drown out the signal. In addition, the number of subscribers had increased to the point where it was not desirable to interrupt the program to speak to a person on the line.

The cable link

When the line was first started, any kind of wire that came to hand was used, and most of it was rusty iron. As the size of the system increased, a frequent popping sound developed which was caused by current jumping bad connections in the line. This would cause a surge which would feed back into the aerial and the line return. This difficulty was overcome by connecting the grounded side of the first rf transformer to a separate ground from the one used for the chasses and output stage.

When the line extended to about ten miles, the volume at the far end became so low as to be quite unsatisfactory, because of excessive losses in the iron wire. A meeting of all the subscribers past a point five miles distant was called, and it was decided that each person would contribute

one dollar to a fund to replace the iron wire with copper. In this way, five miles of copper wire were put up, using telephone-type insulators. The volume at the distant parts of the line was materially improved. From that time on, all new subscribers were required to pay a one dollar fee toward replacing more of the iron conductors with copper wire (see accompanying map on page 74.)

During the summer months, the static was often so bad, even at night, that it was impossible to receive a satisfactory program. To increase the scope of the service, a "local talent" program was inaugurated—the local talent being quite plentiful during the summer months. A ribbon microphone and pre-amplifier were constructed and connected to the audio input (Fig. 4). A phonograph turntable and pickup also supplemented the home talent program. Many announcements of local interest were made, of which the following are representative: "Mrs. Jones has a cow for sale," and "There will be an ice cream supper at Oak Grove School House at seven o'clock Friday evening. Everybody invited."

Test methods and equipment

Since all subscribers were required to put up their own lines and purchase and connect their own speakers, it is not surprising that many grounds and short circuits developed, tending to reduce the volume at other speakers. In fact, it was found that under existing conditions, more

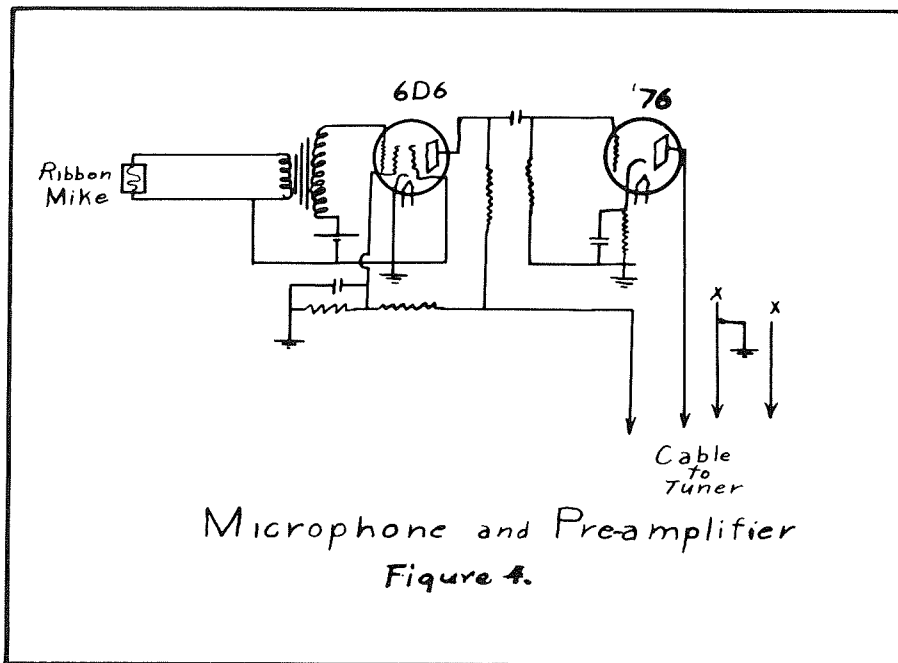

power was dissipated in such grounds than in the speakers themselves. There was also the usual difficulty with broken lines, contact with tree limbs, etc.

As the number of speakers increased, it became necessary to devise some quick method of locating these faults. To do this, a split-core current transformer was made by cutting a slot in the core of an ordinary audio transformer close to the primary winding. The secondary was connected by means of a shielded cable to an audio amplifier in the test car. This amplifier

consisted of a two-stage audio system feeding into an ac voltmeter of the copper oxide rectifier type. The current transformer was mounted on the end of a pole which was normally carried on the side of the test car. When tests were to be made, all subscribers were advised that something was wrong and were asked to turn off their speakers. Then the 110-volt, 60 Hz supply was connected to the line through a resistor. The tests for excessive current along the line were made by raising the current transformer on the pole until

the line slipped in the slot provided for it and observing the calibrated output voltmeter. Although the indications were only approximate, the device was sufficiently sensitive to indicate the current taken by a single speaker and served well to locate ground points.

In one summer, line-loss tests showed that approximately half of the audio power was lost in the first six miles of copper wire. (The majority of the speakers were connected through this line. See map). To reduce this loss and provide greater volume to the more distant points, the six-mile line of wire was changed from a low impedance to a high impedance line, with the audio voltage reaching a maximum of about 800 volts. A transformer at the far end of the line (Five Forks) stepped this down to about 150 volts. This portion of the line was carefully maintained and protected by a relay system. The line was isolated for dc by the use of capacitors, and a constant negative voltage was applied to it through a 100,000-ohm resistor. The line was also connected through a filter system to the grid of a tube. When the line was in good condition, as far as leakage and grounds were concerned, it was maintained at a high negative potential through the 100,000-ohm resistor. This potential, applied to the grid of a tube, prevented the flow of the plate current. If a ground occurred, or if any person touched the line, the resulting flow of the current through the 100,000-ohm resistor lowered the grid voltage on the tube and permitted it to draw a plate current through a relay. The relay opened the primary of the plate supply transformer to the output stage and also closed a signal bell circuit until the fault was removed.

This arrangement was also useful as a signalling device by the tester when calling the sending point from any place on the high impedance line. Even a superficial ground tripped the plate voltage and rang a bell. The person operating the radio then threw a switch which connected a standard telephone transmitter, receiver, and induction coil on the line. The tester also connected a telephone and a two-way conversation between the operator and tester could then be carried on.

Tonal quality

Since the very beginning of the system, frequent improvements were made in tonal quality. These included the change from a three-stage transformer-coupled audio system to a two-stage resistance-coupled circuit with pentode output; a change from

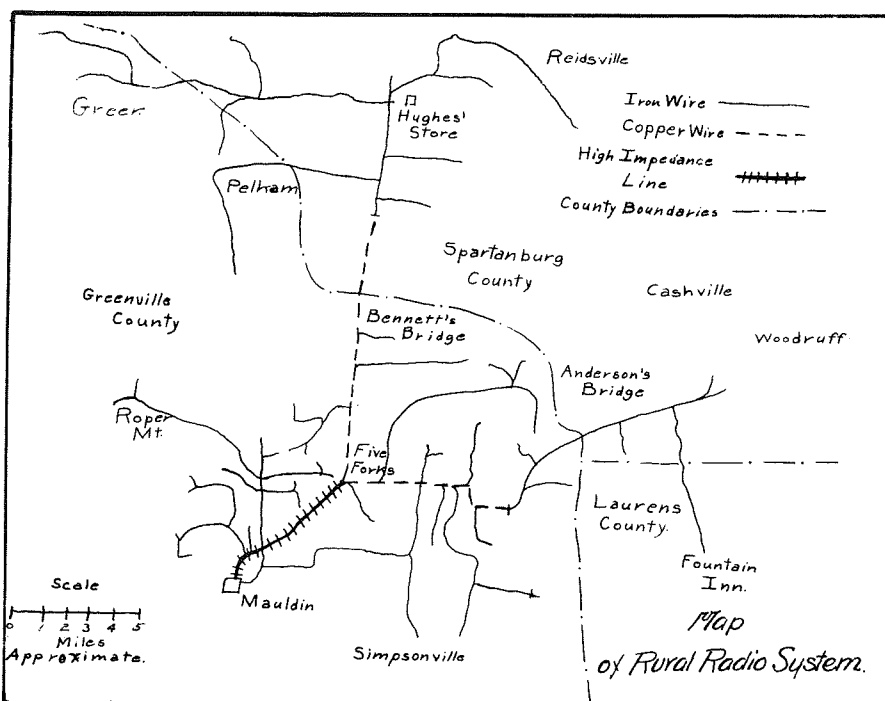

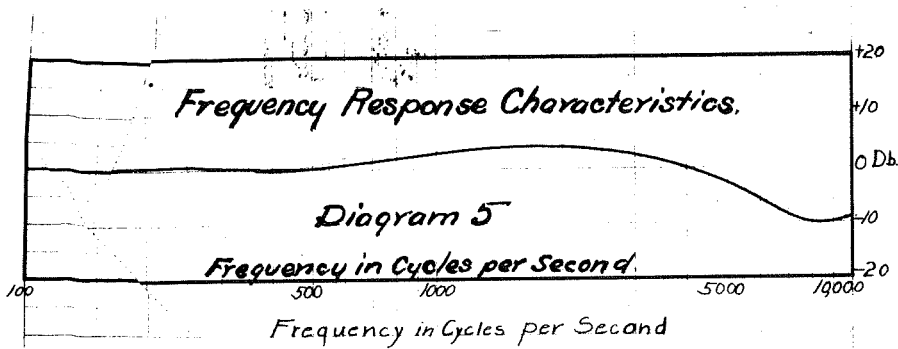

Fig. 5.

pentode output to push-pull triode output; and a change from choke-condenser coupling to transformer coupling of the output. The final system contained only two audio transformers — the push-pull input and the output for the final power stage.

The original output transformer was a partially rewound power transformer. However, a new transformer was designed and wound on the best grade of Allegheny audio iron and treated to exclude moisture. With this transformer in the output stage, the tonal quality surpassed that of any stock radio.

To assist in locating the source of distortion and the causes of low fidelity, a cathode ray oscillograph was constructed around the RCA 906 tube. A beat-note oscillator designed to have a good waveform was also constructed. These two pieces of equipment made possible accurate tests for distortion and fidelity. The results of a test of the frequency characteristics are shown in Fig. 5. In obtaining data for this curve, the oscillograph was used to keep the voltage input constant, as well as for measuring the frequency of the oscillator and checking its waveform.

The following example shows the varied uses to which the oscillograph was put. The output stage had developed a popping noise on high-signal levels, which was caused by either a breakdown in the transformer or a parasitic oscillation in the final stage. By connecting a variable signal voltage to the input of the final stage and observing the waveform in the secondary of the output transformer, it was clear that there was a breakdown in the transformer primary because the break in the sine wave occurred as the secondary voltage approached zero.

Some problems and their solutions

A few of the difficulties encountered outside the system may be of interest. These

consisted of the usual atmospheric disturbances, leakage on power lines, contacts in electric incubators, and telephone line interference. The latter proved the most difficult to solve. Though the telephone lines and the radio distribution system were no nearer than a quarter mile at any point, the programs appeared on the phone lines. The interference was finally eliminated by feeding the various lines in such a way that the local ground current to one group of lines was balanced by that of the other. Thus, the local ground current was practically zero. This might be compared to an Edison 3-wire system with the local ground as neutral.

The objectionable "hash" caused in the receiver by the 866-A mercury vapor rectifiers was overcome by moving the rectifier system to another room and by using shielding and bypass capacitors.

Improvements and alterations

An automatic tuning system was added to permit automatic station selection during a twelve-hour period. The tuning device was designed to eliminate the backlash and slight inaccuracies usually associated with such devices. Another change was the use of a wired wireless system operating at about 40 or 50 kHz to permit tying in, *for signal pickup only*, with another system designed and built, but not owned, by the author. This system also permitted the use of repeater amplifiers at any point on the line accessible to the public service power line. This was important when the lines began to approach a length of 25 miles.

Familiarity with the people served by the system over the years served to indicate the value of the system as an educational medium, despite the fact that a large percentage of the programs was anything but cultural in type. Many of the subscribers did not take newspapers, and practically all new customers asked for "Hill-Billy" or "Fiddlin" programs and music. After several years of reception,

however, they wanted better programs, were more conversant on a greater variety of subjects, and took more interest in outside events.

The combined systems could reach an audience of over 3,000 listeners, and presented distinct possibilities for commercialized advertising.

Although it might seem that there would be dissatisfaction with the program fare, most of the listeners were well pleased and would not part with their "radio." In the 23-mile radius covered by the line, practically 85 percent of the families had speakers.

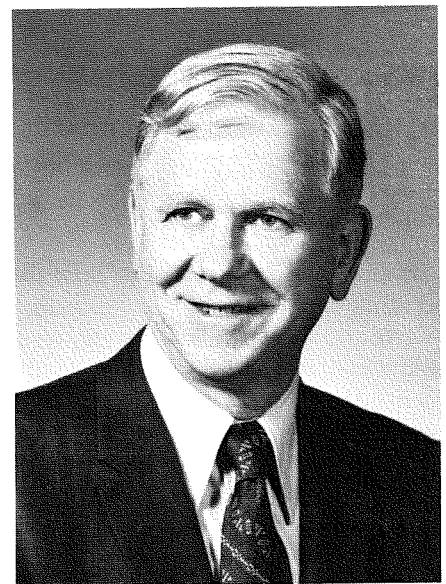

Gordon Rogers, formerly of Consumer Electronics and now retired, joined RCA in 1946 in the Industry Service Laboratory, (ISL), in New York City. ISL provided a consulting engineering service to the licensees of RCA. In 1950, he was made Engineer-in-Charge of the Hollywood ISL and in 1953, of the Chicago ISL. In 1958, Gordon was responsible for the development of citizens band radio transceivers in the Communications Products Department. In 1960, he was made Manager of Advanced Development for the Communication Products Department and in 1963, Manager of Advanced Development for the Home Instruments Division. From 1968 until his retirement he held various managerial positions at CE Video Tape Recorder Engineering, Recorded Video Engineering, and Advanced Development Programs.

He holds 19 U.S. Patents. The most important was filed in 1948 on a system of providing keyed Automatic Gain Control (AGC) for TV receivers. The patent was based on ideas conceived but not used for AGC in the radio described in this article. By 1936 there were at least 12 other similar systems. This paper was presented in 1936 at Clemson College to a meeting of the Southeast district conference of the student AIEE.